

VOH501 Series Metric Manhole Cover

Liquip offers a 500mm (20") diameter cast aluminium manhole cover to suit the specification of oil companies and transport fleets. Liquip's VOH500 Series Manhole come with three equipment mounting positions for overfill protection, vapour recovery and Dip & Fill accessories. Now supplied in metric.

Australian & CEN drop test approval makes these manholes ideal for both top and bottom loading.

Key Features

- Passes Australian & CEN drop tests.
- Cast aluminium lightweight & durable construction
- Two stage opening mechanism enables internal pressure to be released before completely opening the manhole cover.
- 225mm (9") Emergency pressure vent to enable bulk pressure release in event of a fire or rollover..
- Emergency vent doubles as an easy to open inspection hatch for top loading or visual inspection.
- Can be fitted with a 1" thermal pressure & vacuum vent complying with recognised industry codes (for thermal expansion purposes).
- Threaded mounting holes are metric and any mounting positions not utilised can be securely blanked off until required.
- Available with either plain or lockable handle.
- Available with or without direct probe mount.
- Secure Locking Feature via Gravity Latch or Lockable Bridge & Handle.

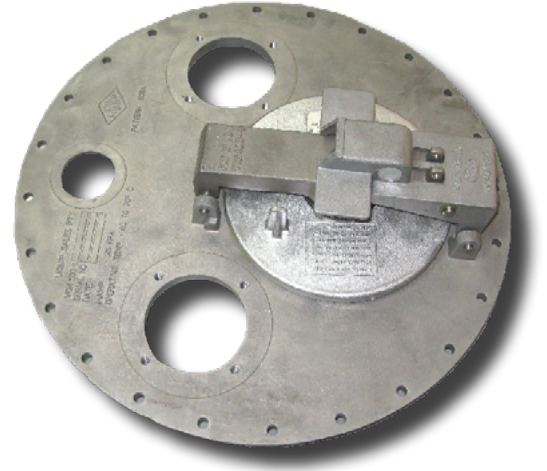

Liquip VOH501 series shown

Specifications

Regulations	Passes the Australian & CEN drop Tests.
Mounting	Mounts onto coaming welded into tanker walkway. VOH500-17M: Steel coaming (hole required: approx Ø503mm) VOH500-14A: Aluminium coaming 5083 alloy H116 (hole required: approx Ø516mm)
Weight	12.0kg (without coaming & mounted accessories)
Adjustment or Service	Periodically check the seals & gaskets, check emergency vent for correct opening pressure.
Materials	All major components are aluminium. All seals are nitrile rubber. Coamings can be supplied in aluminium or steel on request (normally supplied by tank manufacturer).
Associated Equipment	VOH500-14A: Aluminium coaming. VOH500-17M: Steel coaming J237Z: Blank Plate for accessory mounting positions. PJB500: Overfill Probe Holder. VOH400-10: Lock Key.

VOH501 MANHOLE

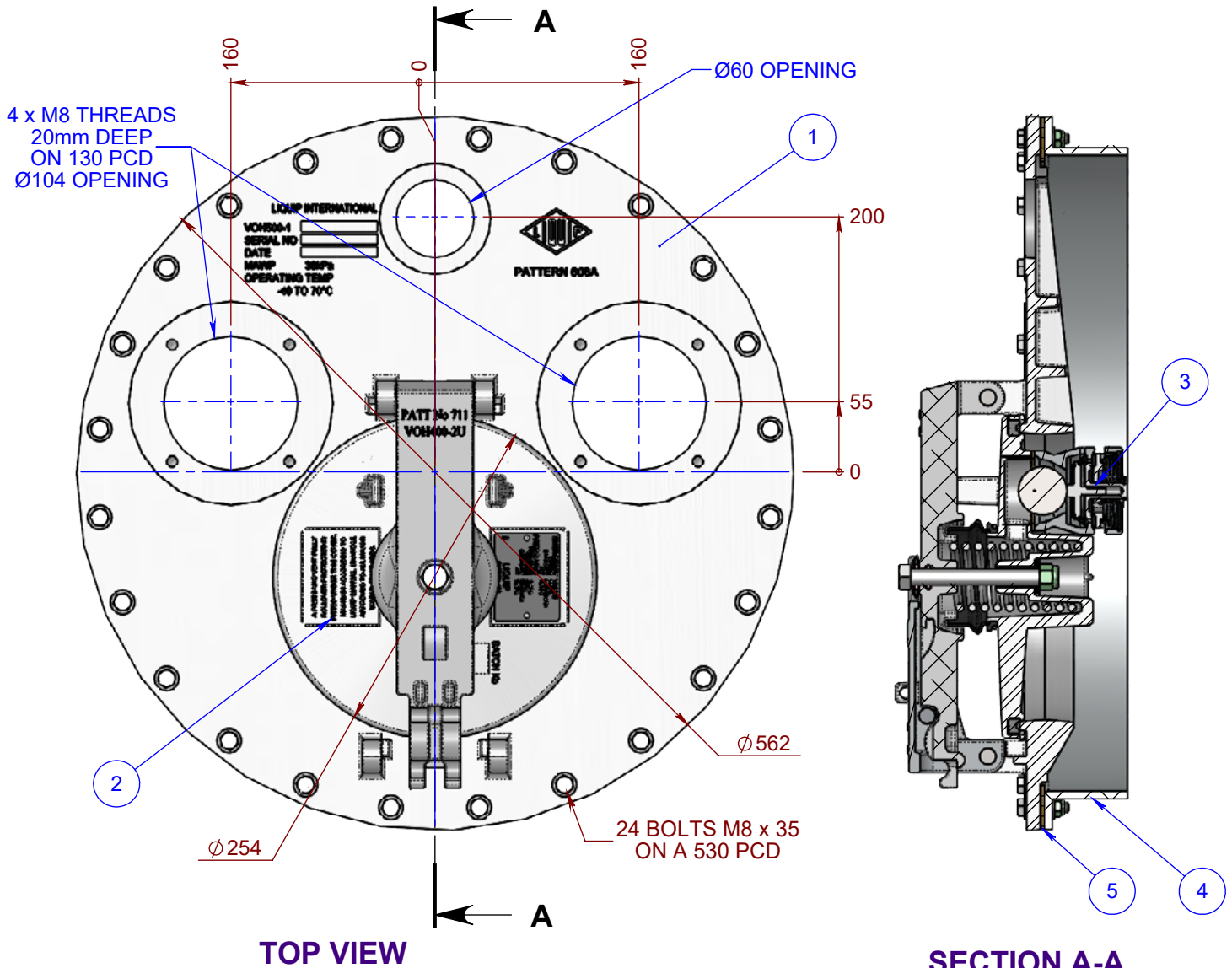

ITEM 2: MODEL SHOWN WITH PLAIN HANDLE, 30kPa SPRING & LABEL FOR PVV104M (SUB-ASSEMBLY VOH501-32A)
 VARIANTS: PLAIN HANDLE, 20kPa (3 PSI) SPRING & LABEL FOR PVV104M (SUB-ASSEMBLY VOH501-32B)
 PLAIN HANDLE, 30kPa SPRING & LABEL FOR PVV104UM (SUB-ASSEMBLY VOH501-32U)
 LOCKABLE HANDLE, 30kPa SPRING & LABEL FOR PVV104M (SUB-ASSEMBLY VOH501-33A)
 LOCKABLE HANDLE, 20kPa (3 PSI) SPRING & LABEL FOR PVV104M (SUB-ASSEMBLY VOH501-33B)
 LOCKABLE HANDLE, 30kPa SPRING & LABEL FOR PVV104UM (SUB-ASSEMBLY VOH501-33U)

ITEM 3: PRESSURE VACUUM VENT REQUIRED IS DETERMINED BY CONFIGURATION OF ITEM 2.

ITEM 4: MODEL SHOWN WITH ROLLED ALUMINIUM COAMING VOH500-14A
 VARIANT: MILD STEEL COAMING VOH500-17M
 COAMING SUPPLIED SEPARATELY

ITEM 5: GASKET & FASTENER SUB-ASSEMBLY IS SUPPLIED SEPARATELY.

NOT SHOWN: GRAVITY LATCH SUB-ASSEMBLY (ADD IF REQUIRED - VOH501-34Z)

ITEM NO.	PART NUMBER	DESCRIPTION	QTY	MATERIAL
1	VOH501D-1	COVER MANHOLE 20" TO GEN REGULATIONS	1	ALUMINIUM
2	VOH501-32A	EMERGENCY VENT PLAIN BRIDGE & HANDLE	1	ALUMINIUM
3	PVV104M	PRESSURE AND VACUUM VENT	1	ALUMINIUM
4	VOH500-14A	COAMING FOR VOH500 MANHOLE	1	ALUMINIUM
5	VOH500-36Z	GASKET & FASTENER SUB-ASSEMBLY	1	NBR CORK

EMERGENCY VENT AND BRIDGE ARRANGEMENT

PRESSURE / VACUUM VENT

GRAVITY LATCH

MANHOLE COVER



VOH411 VOH411-1 MANHOLE COVER



VOH451 VOH451-1 MANHOLE COVER

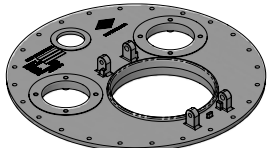

VOH501D VOH501D-1 DIE CAST WITH Ø60.8 PROBE MOUNT

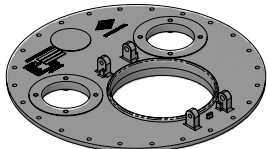

VOH501E VOH501E-1 WITHOUT PROBE MOUNT



VOH750 VOH750-1 MANHOLE COVER



30kPa SPRING (6108) & LABEL 7321

VOH501-32A OPERABLE BRIDGE, PLAIN HANDLE AND EMERGENCY VENT SUB-ASSEMBLY



30kPa SPRING (6108) & LABEL 7321

VOH501-32AVG OPERABLE BRIDGE, PLAIN HANDLE AND EMERGENCY VENT SUB-ASSEMBLY

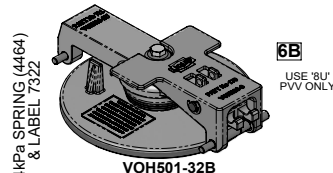

24kPa SPRING (4464) & LABEL 7322

VOH501-32B OPERABLE BRIDGE, PLAIN HANDLE AND EMERGENCY VENT SUB-ASSEMBLY

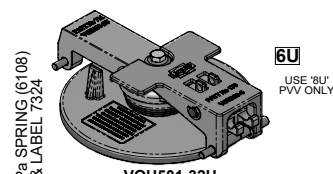

30kPa SPRING (6108) & LABEL 7324

VOH501-32U OPERABLE BRIDGE, PLAIN HANDLE AND EMERGENCY VENT SUB-ASSEMBLY

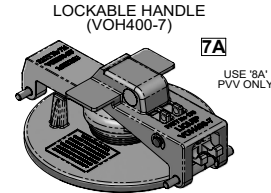

VOH501-33A OPERABLE BRIDGE, LOCKABLE HANDLE AND EMERGENCY VENT SUB-ASSEMBLY

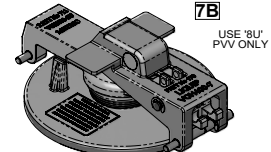

VOH501-33B OPERABLE BRIDGE, LOCKABLE HANDLE AND EMERGENCY VENT SUB-ASSEMBLY

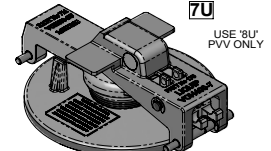

VOH501-33U OPERABLE BRIDGE, LOCKABLE HANDLE AND EMERGENCY VENT SUB-ASSEMBLY

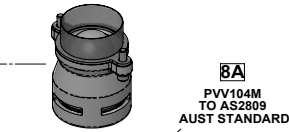

OPENS AT: PRESSURE: 16 ± 1 kPa VACUUM: 2.5 ± 1 kPa
 MUST BE FITTED TO 'A' SERIES EMERGENCY VENTS

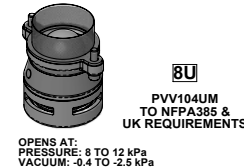

OPENS AT: PRESSURE: 8 TO 12 kPa VACUUM: -0.4 TO -2.5 kPa
 MUST BE FITTED TO 'U' SERIES & 'B' SERIES EMERGENCY VENTS



PVV104-2 BLANKING PLATE
 4250 GASKET NBR CORK
 5269 WASHER SPRING
 55024 CAPSCREW M8 x 30



IF GRAVITY LATCH IS REQUIRED ADD FOLLOWING PARTS:
 1 x VOH700-12 GRAVITY LATCH
 1 x 0096 E-CLIP 1/2"
 1 x 4446 SPRING f. GRAVITY LATCH

VOH 451 6A 8A 0

METRIC ASSEMBLIES

PART NUMBER EXAMPLE FOR VOH451 SERIES MANHOLE, CLAMPBAND STYLE WITH BRIDGE AND PLAIN HANDLE, 30kPa SPRING, PVV104M, NO GRAVITY LATCH. COAMINGS, SEAL AND CLAMPBAND ASSEMBLIES TO BE ORDERED SEPARATELY, SEE LIQUIP DRAWING V90803 FOR PART NUMBERS.

A	RELEASED FOR PRODUCTION	DT	26/08/2020	19/27
REV	REVISION DESCRIPTION	BY	DATE	MCC REF
DRAWING TITLE: VOH SERIES MANHOLES-METRIC - VARIATIONS		LIQUIP PART		VOH MANHOLES-METRIC
MATERIAL:		DRAWN	06/01/03	
HEAT TREATMENT:		ASSY DWG	V90201	
PROTECTIVE TREATMENT:		PART No:		
REMOVE ALL SHARP EDGES AND BURRS		SCALE	NTS	
THIS IS CONFIDENTIAL INFORMATION		MASS		
IF IN DOUBT, ASK!		DRAWN BY	DT	
THIS DRAWING AND DESIGN IS THE PROPERTY OF LIQUIP INTERNATIONAL PTY LTD. IT MUST NOT BE COPIED OR REPRODUCED IN ANY WAY WHATSOEVER WITHOUT WRITTEN AUTHORITY.		ISSUE	A1	Sheet 1 of 1
DRAWING NO		ISSUE		
V90720				